

TEKNISKE DATA

LAST	: 500 kg
LØFTEHØYDE	: 6 m
HEISEHASTIGHET	: 8 / 2 m/min
KATTASTIGHET	: Inverter 2 Steps:20/5 m/min
VEKT AV KATT	: 59 kg
KRANGRUNNE, HEIS	: M5
STRØMTILFØRSEL	: 400 / 48 V; 50 Hz

Pos	Amount	Beskrivelse	Spesifikasjon		
		scrl hu/Norway	Kont	Godkjent	DAS / M@ngo
		Konstruksjon			Vx proj
		2019.10.21			
		Dato			
		Avd			
		SWF KRANTECHNIK	AB-085.1P-N		1:5 M-film
			500kg-Ny		Issue
			scrl hu-000187-1-AB-085.1P-N-O		

SWF Krantechnik reserves the right to alter or amend the above information without notice.
 This document and the information it contains are the exclusive property of SWF Krantechnik and represent a non-public
 confidential and proprietary trade secret that may not be reproduced, disclosed to third parties, altered or otherwise employed in any
 manner whatsoever without the express written consent of SWF Krantechnik GmbH. Copyright © SWF Krantechnik. All rights reserved.

A
B
C
D
E
F
G
H

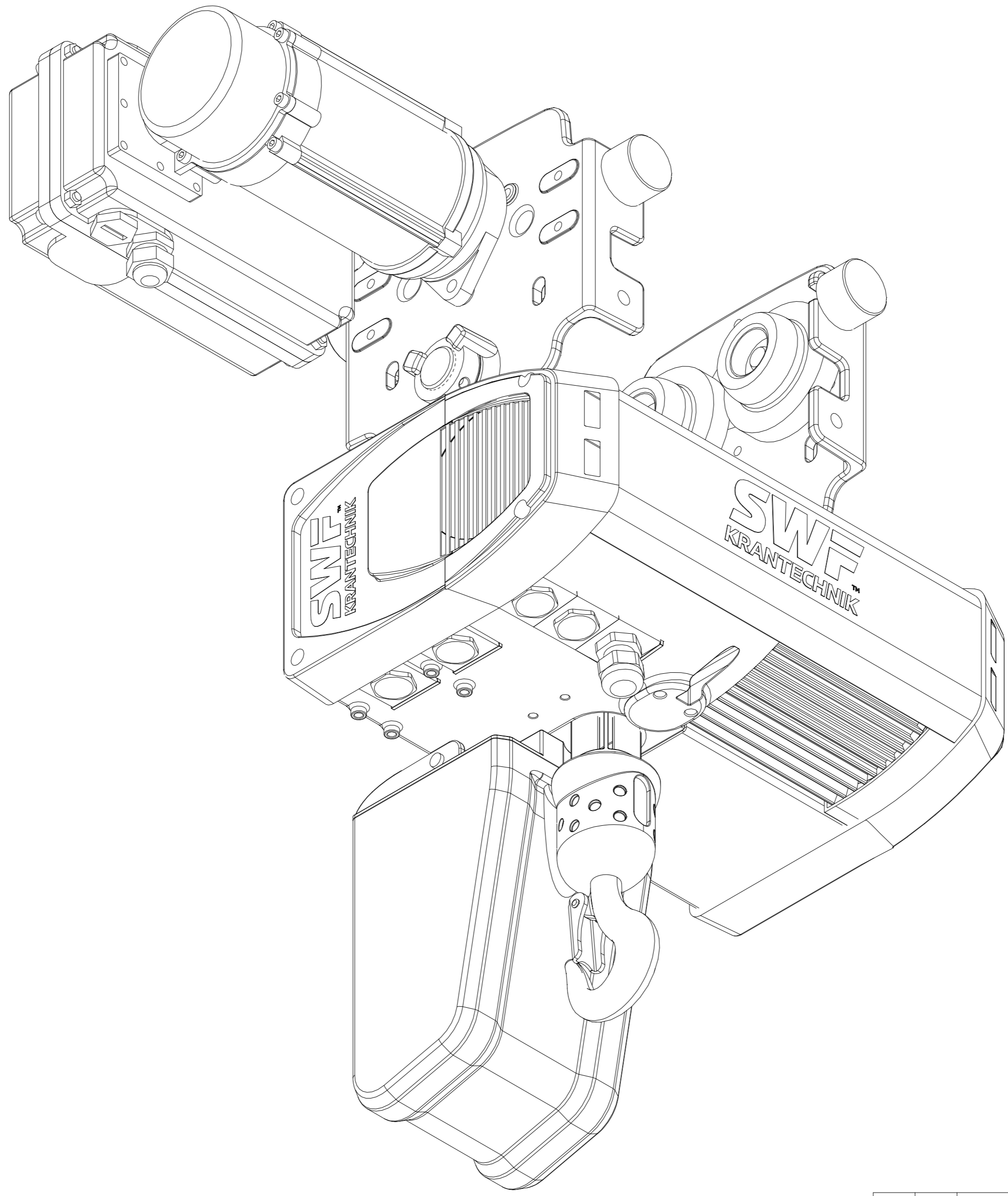

Pos	Amount	Beskrivelse	Spesifikasjon		
		scrlj hu/Norway			DAS / M@ngo
		Konstruksjon	Kont	Godkjent	Ref tegning
		2019.10.21			Vx proj
		Dato			
		Avd			
		SWF KRANTECHNIK™	AB-085.1P-N		1:2.5 M-film
			500kg-Ny		
			scrlj hu-000187-1-AB-085.1P-N-O		Issue

SWF Krantechnik reserves the right to alter or amend the above information without notice.
 This document and the information contained herein, is the exclusive property of SWF Krantechnik and represents a non-patented
 confidential and proprietary trade secret. No part of this document may be reproduced, stored in a retrieval system, or
 transmitted in any form or by any means, electronic, mechanical, photocopying, recording, or otherwise, without the express written consent of SWF Krantechnik GmbH. Copyright © SWF Krantechnik. All rights reserved.