

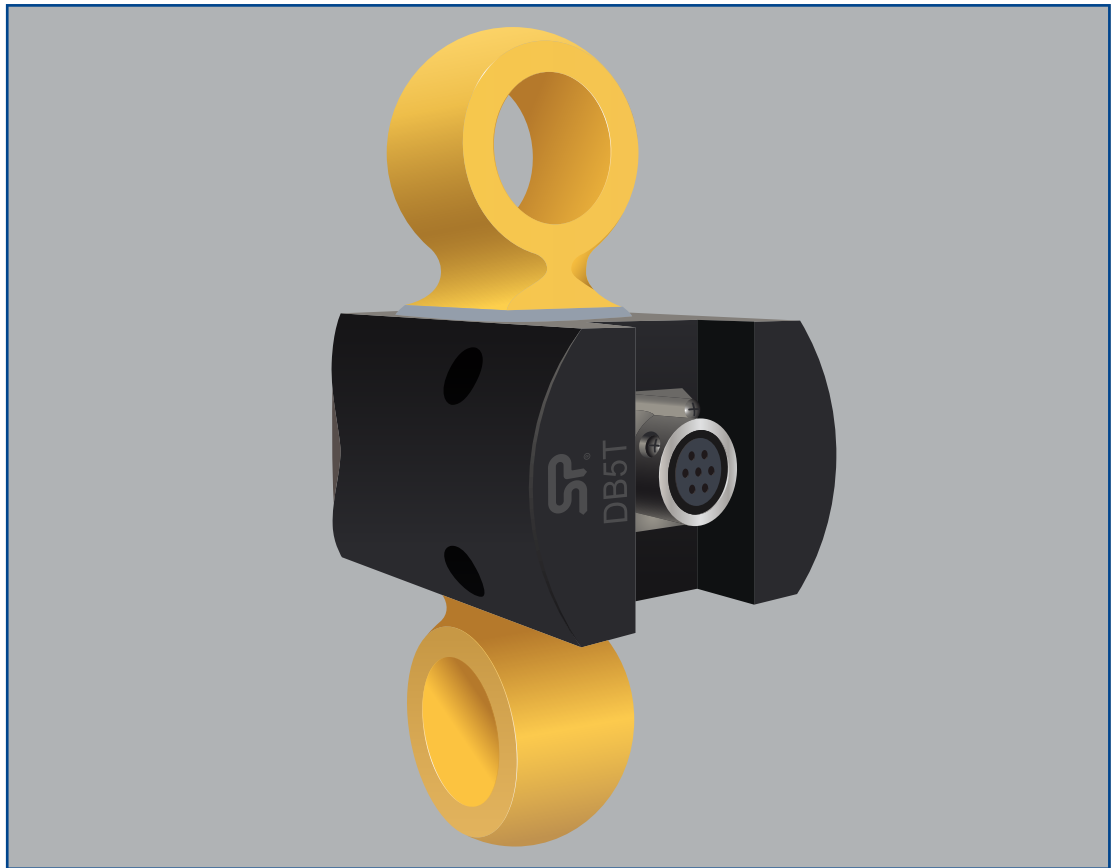

low headroom link



New for 2015 Straightpoint introduces its range of low headroom links designed to provide accurate measurement of loads in the most challenging applications where headroom restrictions are a major factor.

Constructed from high strength alloy steel and exposed to an array of testing during development this impressive range of load cells are designed to work with industry standard shackles from manufacturers such as Crosby and Van Beest. Applications include weighing, lifting, force measurement and load monitoring of structures such as lighting trusses, hoist mountings and fly line tensioning.

The unique low headroom design combines the ability to lift loads with capacities up to 30 tons with state of the art electronics, high accuracy and resolution of over 5000 divisions. Measured loads can be displayed with our Handheld Plus digital display/controller or Windows PC Desktop Controller data logging software.

A vast array of optional output formats are also available to include mV/V, RS-422, RS-485, utilizing the ASCII, MODBUS, TRU and CAN-BUS protocols and analog outputs such as 4-20mA for connection to PLCs, Data Acquisition systems (DAQ) or other required instrumentation. Usable cable length varies greatly, ranging from 10 metres to 1500 metres depending on output format.

A wireless output module is also available on application.



Requires connection to our Handheld Plus (SU3343), our Desktop controller datalogging software package (DCP10M) or our External Amplifier (SA-3420), or other instrumentation.

Features and benefits:

- Low height
- Range from 1t to 30t
- High accuracy
- Lightweight and portable
- Accepts standard shackles
- Constructed from high strength alloy steel
- Huge range of output options
- Connects to Straightpoint data logging software

metric specifications

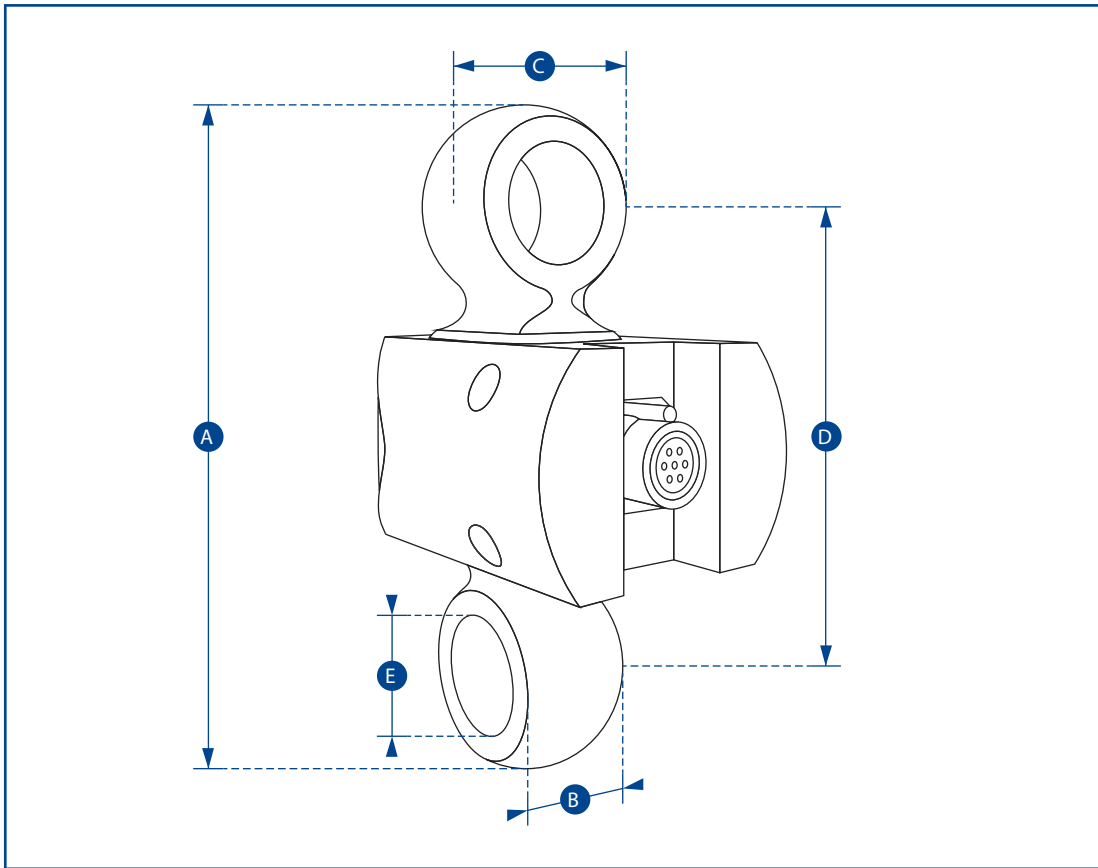

low headroom link

Part Number	DB1T	DB3T	DB5T	DB10T	DB20T	DB30T
Capacity	1000kg	3te	5te	10te	20te	30te
Resolution	0.5kg	0.001te	0.001te	0.002te	0.005te	0.005te
Weight	1kg	1.2kg	2kg	2.5kg	4kg	6.2kg
Safety Factor	5:1					
Operating Temp	-10 to +50°C					
Accuracy	± 0.3 of applied load					
Protection	IP65					
Dimension A	110	129	165	205	249	248
Dimension B	18	25	33	41	66	58
Dimension C	33	35	50	63	90	87
Dimension D	74	88	111	135	153	150
Dimension E Ø	18	21	27	37	53	44
Recommended Shackle	G2130-2T	G2130-3.25T	G2130-6.5T	G2130-12T	G2130-25T	G2140-30T